

# Dimensions of JIS 10K flanges

## JIS 10K フランジの寸法

JIS B 2220  MIE

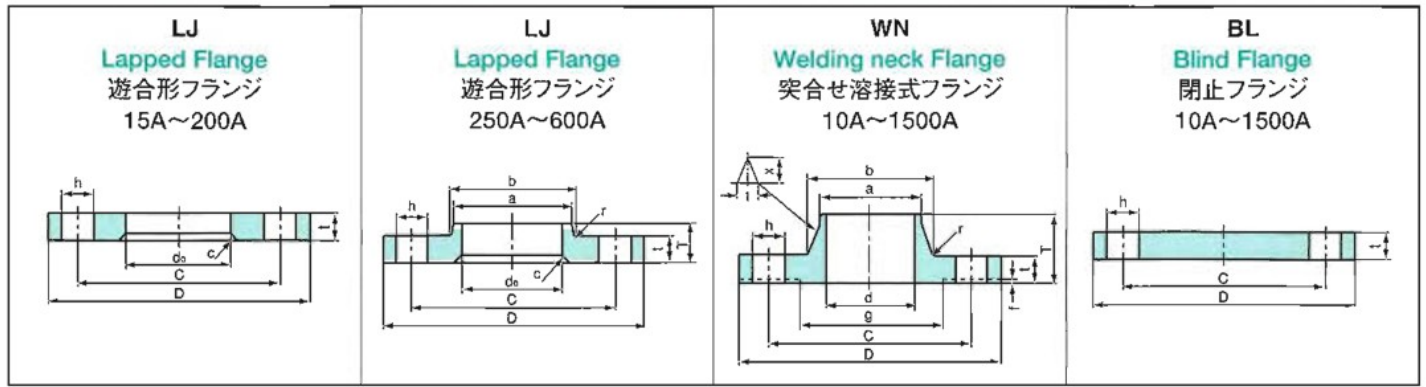

Unit 単位 : mm

Nominal Size 呼び径	Thickness of Flange フランジの厚さ		Diam. of Hub at Small End ハブの径小径側		Diam. of Hub at Large End ハブの径大径側		Taper of Hub ハブのテーパー	Length thru. Hub フランジの全長		Chamfering 面取り (1)	Radius of Fillet at Base of Hub すみ肉の半径		Thick-ness フランジ厚さ	Taper of Hub ハブのテーパー
	Except BL 以外	BL	SOH SW LJ, TR	WN	SOH SW LJ, TR	WN		SOH SW LJ, TR	WN		SOH SW LJ, TR	WN		
	A	t	a		b		x	T		c	r		t	x
10	12		23	17.3	26	28	1.25	16	29	—	4	4	—	—
15	12		27	21.7	30	33	1.25	16	31	3	4	4	—	—
20	14		33	27.2	36	38	1.25	20	32	3	4	4	—	—
25	14		41	34.0	44	47	1.25	20	36	3	4	4	—	—
32	16		50	42.7	53	56	1.25	22	38	4	4	4	—	—
40	16		56	48.6	60	62	1.25	24	38	4	4	4	—	—
50	16		69	60.5	73	75	1.25	24	40	4	4	4	—	—
65	18		86	76.3	91	92	1.25	27	44	5	4	4	—	—
80	18		99	89.1	105	105	1.25	30	45	5	4	5	—	—
90	18		—	101.6	—	117	1.25	—	45	5	—	5	—	—
100	18		127	114.3	130	130	1.25	36	45	5	4	5	—	—
125	20		154	139.8	161	156	1.25	40	47	6	4	5	—	—
150	22		182	165.2	189	184	1.25	40	53	6	4	5	—	—
175	22		—	190.7	—	210	1.25	—	55	—	—	5	—	—
200	22		—	216.3	—	238	1.25	—	58	6	—	5	—	—
225	22		—	241.8	—	261	1.25	—	58	—	—	5	—	—
250	24		288	267.4	292	292	1.25	36	65	6	6	6	—	—
300	24		340	318.5	346	345	1.25	38	68	9	6	6	—	—
350	26		380	355.6	386	388	1.25	42	79	9	6	6	—	—
400	28		436	406.4	442	442	1.25	44	85	9	6	6	—	—
450	30		496	457.2	502	495	1.25	48	90	9	6	6	—	—
500	30	30	548	508.0	554	546	1.5	48	99	9	6	6	40	1.25
550	32	34	604	558.8	610	597	1.75	52	111	9	6	6	42	1.5
600	32	36	656	609.6	662	648	1.75	52	112	9	6	6	42	1.5
650	34	38	706	660.4	712	700	1.75	56	116	—	6	6	44	1.5
700	34	40	762	711.2	770	754	2	58	132	—	6	6	56	1.5
750	36	44	816	762.0	824	807	2	62	139	—	6	6	60	1.5
800	36	46	868	812.8	876	858	2	64	139	—	6	6	60	1.5
850	36	48	920	863.6	928	908	2	66	139	—	6	6	60	1.5
900	38	50	971	914.4	979	959	2	70	140	—	6	6	62	1.5
1000	40	56	1073	1016.0	1081	1065	2	74	151	—	6	6	66	1.5
1100	42	62	1175	1117.6	1185	1174	2	95	170	—	8	10	72	1.5
1200	44	66	1278	1219.2	1290	1281	2	101	182	—	8	10	76	1.5
1350	48	74	1432	1371.6	1450	1438	2	110	200	—	8	10	82	1.5
1500	50	82	1585	1524.0	1605	1598	2	123	218	—	8	12	88	1.5

**Notes:**

- (1) The rounding at radius c is acceptable.
- (2) By the agreement of the delivery parties, these sizes can be adopted.

**注:**

- (1) c の寸法を半径とする丸めでも良い。
- (2) 受け渡し当事者間の協議によって、この寸法としても良い。