

製品情報

対象被削材



技術資料 >> 1995

ISO13399記号 >> 1966

マークの見方 >> 670

エンドミル選定目安表 >> 674

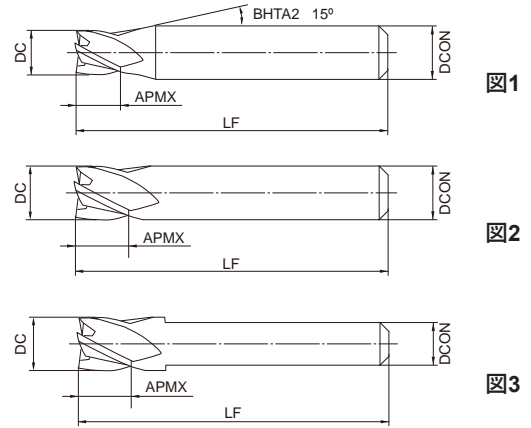

	DC ≤ 12	DC > 12
	0 -0.020	0 -0.030
	4 ≤ DCON ≤ 6	7 ≤ DCON ≤ 10
	0 -0.008	0 -0.009

●標準在庫 単位:mm

呼び記号	DC	APMX	LF	DCON	刃数	在庫	插图
MS4ECD0300L35S04	3	3	35	4	4	●	1
MS4ECD0300L45S04	3	3	45	4	4	●	1
MS4ECD0350L35S04	3.5	3.5	35	4	4	●	1
MS4ECD0350L45S04	3.5	3.5	45	4	4	●	1
MS4ECD0400L35S04	4	4	35	4	4	●	2
MS4ECD0400L45S04	4	4	45	4	4	●	2
MS4ECD0500L35S05	5	5	35	5	4	●	2
MS4ECD0500L35S06	5	5	35	6	4	●	1
MS4ECD0500L45S06	5	5	45	6	4	●	1
MS4ECD0600L35S05	6	6	35	5	4	●	3
MS4ECD0600L35S06	6	6	35	6	4	●	2
MS4ECD0600L45S06	6	6	45	6	4	●	2
MS4ECD0700L35S07	7	6	35	7	4	●	2
MS4ECD0700L45S07	7	7	45	7	4	●	2
MS4ECD0800L35S07	8	6	35	7	4	●	3
MS4ECD0800L35S08	8	6	35	8	4	●	2
MS4ECD0800L45S07	8	8	45	7	4	●	3
MS4ECD0800L45S08	8	8	45	8	4	●	2
MS4ECD1000L35S07	10	6	35	7	4	●	3
MS4ECD1000L35S10	10	6	35	10	4	●	2
MS4ECD1000L45S07	10	10	45	7	4	●	3
MS4ECD1000L45S10	10	10	45	10	4	●	2
MS4ECD1200L35S10	12	6	35	10	4	●	3
MS4ECD1200L45S10	12	12	45	10	4	●	3
MS4ECD1400L45S10	14	14	45	10	4	●	3