

新商品

THRUST CYLINDRICAL ROLLER BEARINGS

スラスト円筒ころ軸受

■特長：大きな動アキシャル荷重を受ける構成の転がり軸受です。



BC□□□□

内輪

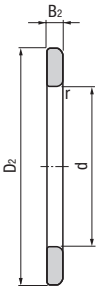

外輪



保持器スラスト円筒ころ

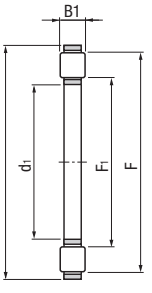

軸受

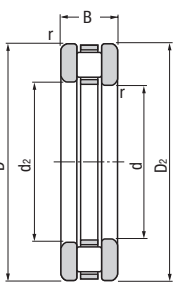

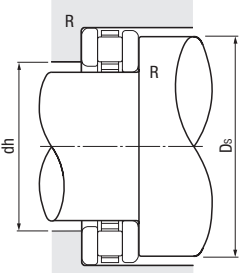

軸受精度 JIS B 1514 0級に準拠
使用温度：100℃以下

構成部品	材質
① 内外輪	M SUJ2
② 保持器	M ポリアミド
③ 円筒ころ	M SUJ2

型式	内輪		外輪		保持器スラスト円筒ころ				軸受		許容回転数 rpm (参考)	基本動定格荷重 Ca kN	基本静定格荷重 Coa kN	取付関係寸法			質量 (g) (参考)	基準単価								
	d	D2	許容差	d2	許容差	D	B2	d1	許容差	D1				許容差	B1	許容差			F1	F	B	r (min.)	Ds (min.)	dh (max.)	R (max.)	
BC1528	15	28		16		28	15	+0.212	28	-0.300			17.2	25.0		9	0.3	2800	12.2	26.8	25	18		26	1,600	
BC1730	17	30		18		30	17	+0.032	30	-0.630	3.5		19.2	27.0				2500	12.7	29.0	27	20	0.3	30	1,650	
BC2035	20	35		21		35	20		35	-0.310	4.5		22.4	32.3	10			2100	20.2	46.5	32	23		40	1,700	
BC2542	25	42		26		42	25	+0.250	42	-0.320	5.0		27.6	38.7		11		1800	27.3	68.0	39	28		60	1,900	
BC3047	30	47		32		47	30	+0.040	47	-0.710			33.1	43.9					27.8	72.5	44		33	0.6	70	2,300
BC3052	30	47		32		47	30		47		7.5		32.8	49.0	16			1500	53.0	129.0	48			140	3,500	
BC3552	35	52		37		52	35		52	-0.340	5.0		38.0	48.9	12			1400	31.0	87.0	49	38		90	2,700	
BC3562	35	62		37		62	35		62	-0.800	7.5		39.8	56.0	18	1.0			54.5	139.0		41	1.0	235	4,000	
BC4060	40	60		42		60	40		60		6.0		43.2	56.4	13	0.6			43.0	121.0		44	0.6	135	2,900	
BC4068	40	68		42		68	40	+0.300	68	-0.360	9.0		43.7	62.9	19	1.0			74.5	190.0	63		1.0	265	4,400	
BC4565	45	65		47		65	45	+0.050	65	-0.340	6.0		48.4	61.6	14	0.6			45.5	135.0	61	49	0.6	150	3,200	
BC4573	45	73		47		73	45		73	-0.800	9.0		48.8	68.0	20	1.0			82.0	222.0	68		1.0	310	4,500	
BC5070	50	70		52		70	50		70	-0.360	6.0		53.2	66.4	14	0.6			48.5	150.0	66	54	0.6	165	3,400	
BC5078	50	78	-0.2	52	+0.5	78	50	+0.2	78	-0.820	9.0	0	53.7	73.1	22	1.0		950	85.0	238.0	73		1.0	385	5,300	
BC5578	55	78	-0.5	52	+0.2	78	55		78		6.0	-0.01	57.8	75.2	16	0.6		900	62.5	215.0	75	58	0.6	250	4,200	
BC5590	55	90		57		90	55		90		11.0		60.1	83.4	25			830	121.0	340.0	83	61		610	6,500	
BC6085	60	85		62		85	60		85		7.5		63.7	80.1	17				69.0	215.0	80	65		285	4,600	
BC6095	60	95		62		95	60		95	-0.380	11.0		64.9	88.4	26				126.0	365.0	88	66		660	6,900	
BC6590	65	90		67		90	65		90	-0.920	7.5		68.8	85.2	18			780	73.0	236.0	85	70		340	7,800	
BC65100	65	100		67		100	65	+0.360	100		11.0		69.9	93.3	27				130.0	385.0	93	71		775	5,300	
BC7095	70	95		72		95	70	+0.060	95		7.5		73.7	90.1	18			730	76.5	257.0	90	74		365	8,200	
BC70105	70	105		72		105	70		105	-0.410	11.0		75.0	98.4	27	1.0			134.0	410.0	98	76	1.0	815	5,600	
BC75100	75	100		77		100	75		100	-0.380	7.5		78.8	95.1	19				78.0	268.0	95	80		425	6,600	
BC75110	75	110		77		110	75		110	-0.920	11.0		80.1	103.7	27				138.0	435.0	103	81		860	9,400	
BC80105	80	105		82		105	80		105	-0.410	7.5		83.7	100.1	19				79.5	279.0	100	85		445	7,200	
BC80115	80	115		82		115	80		115	-0.950	11.0		84.8	108.4	28				143.0	460.0	106	86		950	11,000	
BC85110	85	110		87		110	85	+0.422	110	-0.072	7.5		88.7	105.3	19				83.0	300.0	105	89		475	8,000	

Order 注文例
型式 BC1528

Delivery 出荷日
在庫品 翌日出荷 P.133
ご希望によりPM6:00迄、当日出荷受付け致します。

Price 価格

■数量スライド価格 (1円未満切り捨て) P.133

数量区分	標準対応		個別対応
	小口	大口	
数量	1~9	10~20	21~50
値引率	基準単価	5%	10%

◎表示数量超えはWOSにてご確認ください。

kgf=N×0.101972

14 ベアリングホルダ