

●標準寸法では、突出し長さが不足するような場合に使用します。

This tap is used when a standard SG Spiral Tap is too short.

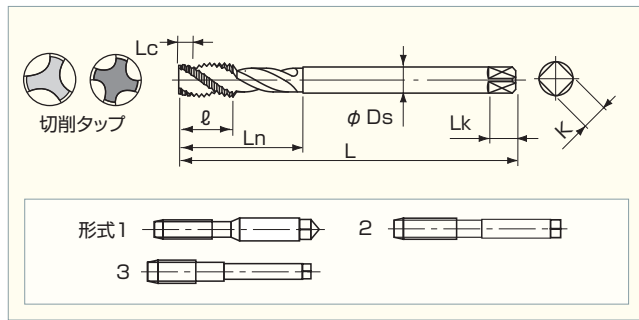

LIST 7948

オーダ方法 **SGSPL** 記号 × 全長

単位 (Unit) : mm

記号 Code No.	全長 L	呼び Thread Size	等級 TAP Limit		食付 (P) Lc (P)	ねじ長 ℓ	溝数 Flutes	シャンク径 Ds	首下長さ Ln	形式 Type	在庫 Stock	参考価格(円) Price (¥)
3M0.5R	100	M3 × 0.5	REG	P2	2.5	5.8	3	4.0	13.0	1	●	4,560
3M0.5R+1			REG+1	P3								4,670
3M0.5R+2			REG+2	P4								4,670
3M0.35R	100	M3 × 0.35	REG	P2	2.5	4.9	3	4.0	13.0	1	●	6,450
3M0.35R+1			REG+1	P3								6,630
3.5M0.6R			REG	P2								2.5
3.5M0.35R	100	M3.5 × 0.35	REG	P2	2.5	4.9	3	4.0	15.0	1	●	7,370
4M0.7R	100	M4 × 0.7	REG	P3	2.5	7.8	3	5.0	17.0	1	●	4,160
4M0.7R+1			REG+1	P4								4,270
4M0.7R+2			REG+2	P5								4,270
4M0.5R	100	M4 × 0.5	REG	P2	2.5	5.8	3	5.0	17.0	1	●	5,460
4M0.5R+1			REG+1	P3								5,590
4.5M0.75R			REG	P2								2.5
4.5M0.5R	100	M4.5 × 0.5	REG	P2	2.5	5.8	3	5.0	19.0	1	●	6,030
5M0.8R	100	M5 × 0.8	REG	P3	2.5	9.5	3	5.5	21.0	1	●	3,720
5M0.8R+1			REG+1	P4								3,830
5M0.8R+2			REG+2	P5								3,830
5M0.5R	100	M5 × 0.5	REG	P2	2.5	5.8	3	5.5	21.0	1	●	4,680
5M0.5R+1			REG+1	P3								4,830
5.5M0.5R			REG	P2								2.5
6M1R	100	M6 × 1	REG	P3	2.5	11.5	3	6.0	25.0	1	●	3,820
6M1R	150		5,100									
6M1R+1	100		REG+1	P4								3,930
6M1R+1	150		5,210									
6M1R+2	100		REG+2	P5								4,040
6M1R+2	150		5,210									
6M0.75R	100	M6 × 0.75	REG	P2	2.5	9.0	3	6.0	25.0	1	●	4,460
6M0.75R	150		6,190									
6M0.75R+1	100		REG+1	P3								4,610
6M0.75R+1	150		6,340									
7M1R	100	M7 × 1	REG	P3	2.5	11.5	3	6.2	25.3	2	●	4,650
7M1R	150		6,250									
7M0.75R	100		REG	P2								2.5
7M0.75R	150	7,980										
8M1.25R	100	M8 × 1.25	REG	P3	2.5	15.1	3	6.2	28.0	3	●	4,490
8M1.25R	150		6,050									
8M1.25R+1	100		REG+1	P4								4,650
8M1.25R+1	150		6,210									
8M1.25R+2	100		REG+2	P5								4,650
8M1.25R+2	150		6,210									
8M1R	100	M8 × 1	REG	P3	2.5	11.5	3	6.2	28.0	3	●	5,050
8M1R	150		7,020									
8M1R+1	100		REG+1	P4								5,240
8M1R+1	150		7,210									
8M0.75R	100	M8 × 0.75	REG	P3	2.5	9.0	3	6.2	28.0	3	●	5,480
8M0.75R	150		7,760									
8M0.75R+1	100		REG+1	P4								5,670
8M0.75R+1	150		7,950									
9M1.25R	100	M9 × 1.25	REG	P3	2.5	15.1	3	7.0	28.6	3	●	5,160
9M1.25R	150		7,210									
9M1R	100	M9 × 1	REG	P3	2.5	11.5	3	7.0	28.6	3	●	5,970
9M1R	150		8,580									
9M0.75R	100		M9 × 0.75	REG								P3
9M0.75R	150	9,540										

新商品

超硬ドリル

ハイスドリル

タップ

超硬
エンドミル

ハイス
エンドミル

切断工具

バック・
セット商品
その他

精密工具

技術資料
索引