

Reamers

Endmills

Drills

Countersinks/
Counterbores

Slitting Saws/
Cut-off tools

Cutters

Cold Circular
Saws

High Power
Slitting Saws

Metal Slitting
Saws

Screw Slotting
Cutters

MS
TMS

メタルソー ノン・コーティング
Metal Slitting Saws Non-coated

メタルソー TiNコーティング
Metal Slitting Saws TiN coated

製品略号 Product code	表面処理 Surface Treatment	切削条件 Cutting Conditions
MS		
TMS		

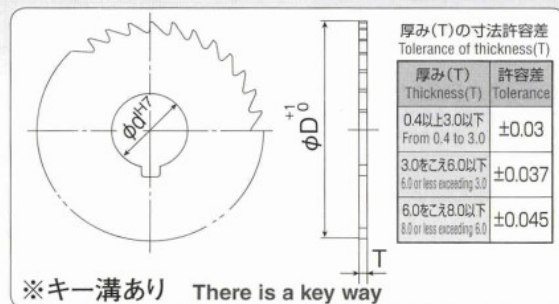

- 金属の溝入れ加工
For slitting work in metals
- 精密切断加工
For precision cutting work

穴径φ25.4 Hole Dia. φ25.4

MS ノン・コーティング		TMS TiNコーティング		寸法 Size			
品番 Product No.	標準価格 Standard price ¥	品番 Product No.	標準価格 Standard price ¥	刃径 D	厚み T	穴径 d	刃数 NT
MST075X004	5,000	TMST075X004	7,100	75	0.4	25.4	48
MST075X005	5,000	TMST075X005	7,100	75	0.5	25.4	48
MST075X006	4,400	TMST075X006	6,000	75	0.6	25.4	48
MST075X007	4,400	TMST075X007	6,000	75	0.7	25.4	48
MST075X008	4,400	TMST075X008	6,000	75	0.8	25.4	48
MST075X009	4,400	TMST075X009	6,000	75	0.9	25.4	48
MST075X010	4,000	TMST075X010	5,500	75	1.0	25.4	48
MST075X011	4,100	TMST075X011	5,700	75	1.1	25.4	48
MST075X012	4,100	TMST075X012	5,700	75	1.2	25.4	48
MST075X013	4,100	TMST075X013	5,700	75	1.3	25.4	48
MST075X014	4,100	TMST075X014	5,700	75	1.4	25.4	48
MST075X015	4,100	TMST075X015	5,700	75	1.5	25.4	40
MST075X016	4,100	TMST075X016	5,800	75	1.6	25.4	40
MST075X017	4,100	TMST075X017	5,800	75	1.7	25.4	40
MST075X018	4,100	TMST075X018	5,800	75	1.8	25.4	40
MST075X019	4,100	TMST075X019	5,800	75	1.9	25.4	40
MST075X020	4,100	TMST075X020	5,800	75	2.0	25.4	40
MST075X021	4,700	TMST075X021	6,500	75	2.1	25.4	40
MST075X022	4,700	TMST075X022	6,500	75	2.2	25.4	40
MST075X023	4,700	TMST075X023	6,500	75	2.3	25.4	40
MST075X024	4,700	TMST075X024	6,500	75	2.4	25.4	40
MST075X025	4,700	TMST075X025	6,500	75	2.5	25.4	40
MST075X026	4,900	TMST075X026	6,900	75	2.6	25.4	40
MST075X027	4,900	TMST075X027	6,900	75	2.7	25.4	40
MST075X028	4,900	TMST075X028	6,900	75	2.8	25.4	40
MST075X029	4,900	TMST075X029	6,900	75	2.9	25.4	40
MST075X030	4,900	TMST075X030	6,900	75	3.0	25.4	40
MST075X031	5,200	TMST075X031	7,300	75	3.1	25.4	40
MST075X032	5,200	TMST075X032	7,300	75	3.2	25.4	40
MST075X033	5,200	TMST075X033	7,300	75	3.3	25.4	40
MST075X034	5,200	TMST075X034	7,300	75	3.4	25.4	40