

SPPD ブランチティー ネジ部材質：PP

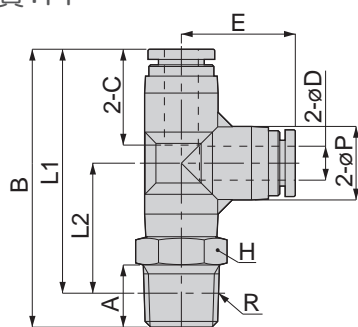

単位：mm

形式	チューブ外径 øD	R	A	B	L1	L2	øP	チューブ径 C	E	対辺 H	質量 (g)	オリーブ径 (ømm)	価格 (¥)
SPPD4-01	4	R1/8	8	40.1	36.1	19.2	10	14.9	16.9	10	5.6	2.5	740
SPPD4-02		R1/4	11	43.1	37.1	20.2				14	6.3		750
SPPD6-01	6	R1/8	8	46.2	42.2	22	13	17	20.1	12	7.8	4	770
SPPD6-02		R1/4	11	49.2	43.1	23				14	8.5		770
SPPD6-03		R3/8	12	51	44.6	24.5				17	9.3		790
SPPD8-01	8	R1/8	8	50.4	46.4	24.2	15	18.1	22.2	14	11	6	850
SPPD8-02		R1/4	11	53.4	47.4	25.2				14	12		850
SPPD8-03		R3/8	12	55.2	48.9	26.7				17	13		870
SPPD10-02	10	R1/4	11	61.2	55.2	30	17.5	20.2	25.2	17	18	7.5	1,120
SPPD10-03		R3/8	12	62.2	55.9	30.7					19		1,120
SPPD12-03	12	R3/8	12	67.6	61.3	32.9	21	22.9	28.2	22	27	9	1,330
SPPD12-04		R1/2	15	70.6	62.4	34					28		1,330

※L1、L2寸法は、ねじ締付け後の参考寸法です。

SPPX ブランチワイ ネジ部材質：PP

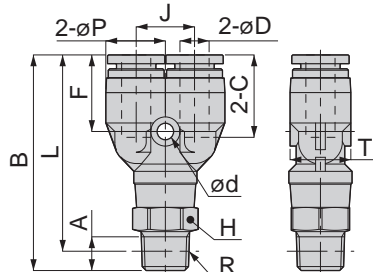

単位：mm

形式	チューブ外径 øD	R	A	B	L	øP	チューブ径 C	J	ød	F	対辺 H	T	質量 (g)	オリーブ径 (ømm)	価格 (¥)
SPPX4-01	4	R1/8	8	40.6	36.6	10	14.9	11	3.2	14.1	10	10.4	5.9	2.5	740
SPPX4-02		R1/4	11	43.6	37.6						14		6.7		750
SPPX6-01	6	R1/8	8	44.4	40.4	12.5	17	12	3.4	15.8	12	13.5	8	4	770
SPPX6-02		R1/4	11	47.4	41.3						14		8.7		770
SPPX6-03		R3/8	12	49.2	42.8						17		9.5		790
SPPX8-01	8	R1/8	8	48.7	44.7	14.5	18.1	14	3.4	17.2	14	15.1	12	5.9	850
SPPX8-02		R1/4	11	51.7	45.7						14		13		850
SPPX8-03		R3/8	12	53.5	47.2						17		13		870
SPPX10-02	10	R1/4	11	58.3	52.3	18	20.7	18	4.5	19.5	17	18	20	6.7	1,120
SPPX10-03		R3/8	12	59.3	53								21		1,120
SPPX12-03	12	R3/8	12	64.5	58.2	21	23.4	20	4.2	22.2	22	21	29	7.9	1,330
SPPX12-04		R1/2	15	67.5	59.3								30		1,330

※L寸法は、ねじ締付け後の参考寸法です。