

VH 電磁弁直付形エルボタイプ (大気開放)

RoHS対応

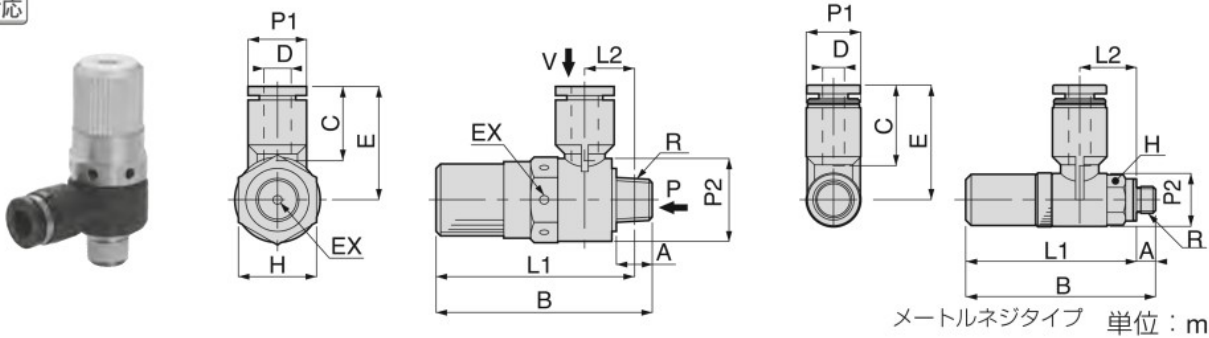

メートルネジタイプ 単位：mm

形式	チューブ径 D	R	A	B	L1	L2	P1	P2	C	E	対辺 H	ノズル径 (mm)	使用圧力 (MPa)	到達真空度 (-kPa)	吸入流量 (l/min/ANR)	消費流量 (l/min/ANR)	質量 (g)	CAD ファイル名						
VHH05-4M5	4	M5×0.8	3.5	35	31.5	10.5	10	9.8	14.9	21.2	8	0.5	0.5	90	7	11.5	13	VH_05-4M5						
VHH05-601	6	R1/8	8	48	44	11.4	12.4	18.4	17	25.5	17	0.7						93	13	23	37	VH_601		
VHH10-601												1										28	46	
VHH12-601												1.2										38	70	
VHH10-801	8	R1/8	8	48	44	12.4	14.4	18.1	18.1	28.4	17	1						93	28	46	38	VH_801		
VHH12-801												1.2										38	70	
VHH15-802	10	R1/4	11	71.5	65.5	13.5	14.5	22	20.2	31.2	22	1.5						93	63	100	77	VH_15-802		
VHH15-1002																						14.8	80	VH_15-1002
VHH20-1002	10	R3/8	12	100.6	94.2	15.8	17.6	28	20.2	33.6	24	2						93	104	200	116	VH_20-1002		
VHH20-1003																						126	VH_20-1003	
VHH20-1202	12	R1/4	11	99.6	93.5	16.8	21	23.4	36.4	24	2	93	104	200	116	116	VH_20-1202							
VHH20-1203																	R3/8	12	100.6	94.2	17.5	126	VH_20-1203	
VHL05-4M5	4	M5×0.8	3.5	35	31.5	10.5	10	9.8	14.9	21.2	8	0.5	0.5	66	12	11.5	13	VH_05-4M5						
VHL05-601	6	R1/8	8	48	44	11.4	12.4	18.4	17	25.5	17	0.7						93	26	23	37	VH_601		
VHL10-601												1										42	46	36
VHL07-801												0.7										26	23	39
VHL10-801	8	R1/8	8	48	44	12.4	14.4	18.1	18.1	28.4	17	1						93	42	46	38	VH_801		
VHL15-802												13.5										14.5	22	28.9
VHL15-1002	10	R1/4	11	71.5	65.5	14.8	17.6	22	20.2	31.2	22	1.5						93	95	100	78	VH_15-1002		
VHL15-1202																						12	16.5	21
VHL20-1002	10	R3/8	12	100.6	94.2	15.8	17.6	28	20.2	33.6	24	2						93	174	200	116	VH_20-1002		
VHL20-1003																						126	VH_20-1003	
VHL20-1202	12	R1/4	11	99.6	93.5	16.8	21	23.4	36.4	24	2	93	174	200	116	116	VH_20-1202							
VHL20-1203																	R3/8	12	100.6	94.2	17.5	126	VH_20-1203	
VHE07-601	6	R1/8	8	48	44	11.4	12.4	18.4	17	25.5	17	0.7	92	10.5	17	37	VH_601							
VHE10-601												1					21	34						
VHE12-601												1.2					27	47						
VHE10-801	8	R1/8	8	48	44	12.4	14.4	18.1	18.1	28.4	17	1	92	21	34	39	VH_801							
VHE12-801												1.2					27	47						
VHE15-802	10	R1/4	11	71.5	65.5	13.5	14.5	22	20.2	31.2	22	1.5	92	42	70	78	VH_15-802							
VHE15-1002																	14.8	80	VH_15-1002					
VHE20-1002	10	R3/8	12	100.6	94.2	15.8	17.6	28	20.2	33.6	24	2	92	82	150	116	VH_20-1002							
VHE20-1003																	126	VH_20-1003						
VHE20-1202	12	R1/4	11	99.6	93.5	16.8	21	23.4	36.4	24	2	92	82	150	116	116	VH_20-1202							
VHE20-1203																	R3/8	12	100.6	94.2	17.5	126	VH_20-1203	

※. テーパネジタイプのL1, L2寸法は、ねじ締付け後の参考寸法です。