

REAR Series

外形寸法図

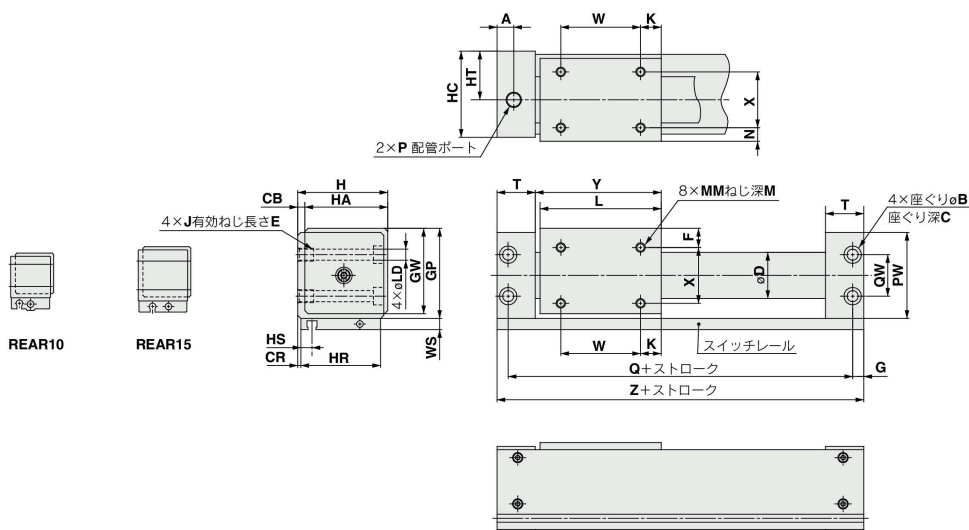

(mm)

型式	A	B	C	CB	CR	D	F	G	GP	GW	H	HA	HC	HR	HS	HT	J×E
REAR10	10.5	6.5	3.2	2	0.5	12	6.5	6	27	25.5	26	24	25	24	5	14	M4×0.7×6
REAR15	12	8	4.2	2	0.5	17	8	7	33	31.5	32	30	31	30	8.5	17	M5×0.8×7
REAR20	9	9.5	5.2	3	1	22.8	9	6	39	37.5	39	36	38	36	7.5	21	M6×1×8
REAR25	8.5	9.5	5.2	3	1	27.8	8.5	6	44	42.5	44	41	43	41	6.5	23.5	M6×1×8
REAR32	10.5	11	6.5	3	1.5	35	10.5	7	55	53.5	55	52	54	51	7	29	M8×1.25×10
REAR40	10	11	6.5	5	2	43	13	7	65	63.5	67	62	66	62	8	36	M8×1.25×10

型式	K	L	LD	M	MM	N	P			PW	Q	QW	T	W	WS	X	Y	Z
							無記号	TN	TF									
REAR10	9	38	3.5	4	M3×0.5	4.5	M5×0.8	—	—	26	68	14	19.5	20	8	15	39.5	80
REAR15	14	53	4.3	5	M4×0.7	6	M5×0.8	—	—	32	84	18	21	25	7	18	54.5	98
REAR20	11	62	5.6	5	M4×0.7	7	Rc1/8	NPT1/8	—	38	95	17	20.5	40	7	22	64	107
REAR25	15	70	5.6	6	M5×0.8	6.5	Rc1/8	NPT1/8	G1/8	43	105	20	21.5	40	7	28	72	117
REAR32	13	76	7	7	M6×1	8.5	Rc1/8	NPT1/8	G1/8	54	116	26	24	50	7	35	79	130
REAR40	15	90	7	8	M6×1	11	Rc1/4	NPT1/4	—	64	134	34	26	60	7	40	93	148