

リングシールタイプアダプター

- Material : Plated steel
- 材質 : SS(三価クロメートメッキ)

**SWO3LB (同径)**

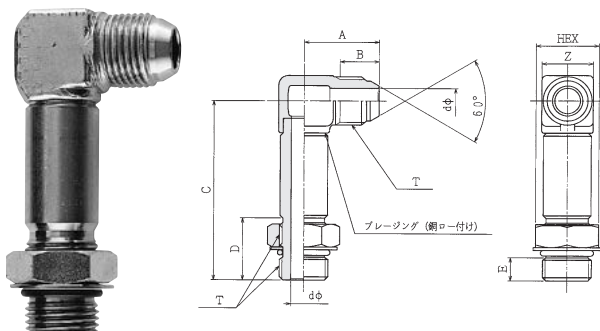

呼び径	ねじT	Amm	Bmm	Cmm	Dmm	Emm	dφmm	Zmm	HEXmm
6	G ¼	24.0	11.5	63.0	21.0	7.5	5.5	14	19
9	G ⅜	27.5	13.5	68.0	24.0	8.8	8.0	19	22
12	G ½	32.5	15.5	78.0	27.0	10.0	11.0	22	27
19	G ¾	36.5	17.5	90.3	30.0	11.0	16.0	30	32
25	G 1	40.5	18.5	102.0	33.0	12.0	22.0	36	41

**SWO3LB-1、SWO3LB-2 (異径)**

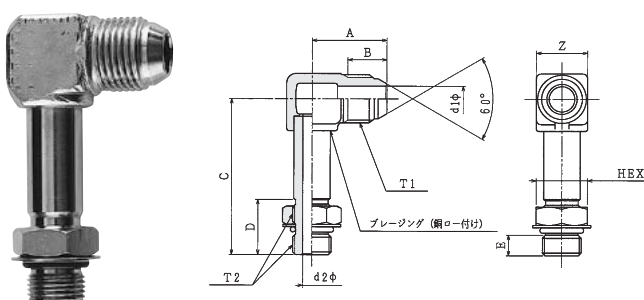

	呼び径	ねじT <sub>1</sub>	ねじT <sub>2</sub>	Amm	Bmm	Cmm	Dmm	Emm	d <sub>1</sub> φmm	d <sub>2</sub> φmm	Zmm	HEXmm
1	9×6	G ⅜	G ¼	27.5	13.5	63.0	21.0	7.5	8.0	5.5	19	19
	12×9	G ½	G ⅜	32.5	15.5	68.0	24.0	8.8	11.0	8.0	22	22
	19×12	G ¾	G ½	36.5	17.5	78.0	27.0	10.0	16.0	11.0	30	27
	25×19	G 1	G ¾	40.5	18.5	90.3	30.0	11.0	22.0	16.0	36	32
2	6×9	G ¼	G ⅜	24.0	11.5	68.0	24.0	8.8	5.5	8.0	14	22
	9×12	G ⅜	G ½	27.5	13.5	78.0	27.0	10.0	8.0	11.0	19	27
	12×19	G ½	G ¾	32.5	15.5	90.3	30.0	11.0	11.0	16.0	22	32
	19×25	G ¾	G 1	36.5	17.5	102.0	33.0	12.0	16.0	22.0	30	41

**SWO4LB (同径)**

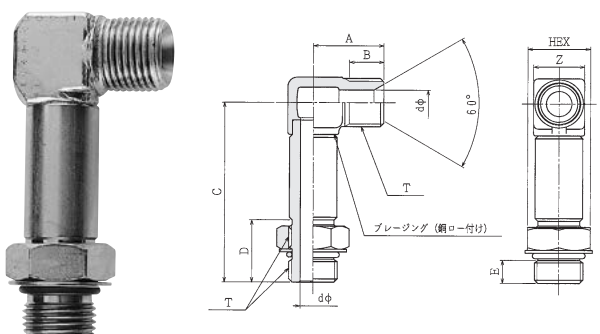

呼び径	ねじT	Amm	Bmm	Cmm	Dmm	Emm	dφmm	Zmm	HEXmm
6	G ¼	22.0	10.1	63.0	21.0	7.5	5.5	14	19
9	G ⅜	25.0	12.0	68.0	24.0	8.8	8.0	19	22
12	G ½	30.5	15.0	78.0	27.0	10.0	11.0	22	27
19	G ¾	35.0	17.0	90.3	30.0	11.0	16.0	30	32
25	G 1	40.0	18.0	102.0	33.0	12.0	22.0	36	41

**SWO4LB-1、SWO4LB-2 (異径)**

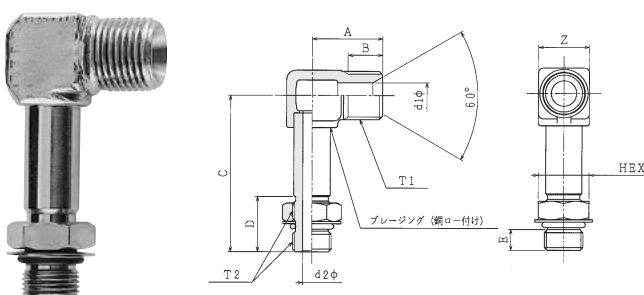

	呼び径	ねじT <sub>1</sub>	ねじT <sub>2</sub>	Amm	Bmm	Cmm	Dmm	Emm	d <sub>1</sub> φmm	d <sub>2</sub> φmm	Zmm	HEXmm
1	9×6	G ⅜	G ¼	25.0	12.0	63.0	21.0	7.5	8.0	5.5	19	19
	12×9	G ½	G ⅜	30.5	15.0	68.0	24.0	8.8	11.0	8.0	22	22
	19×12	G ¾	G ½	35.0	17.0	78.0	27.0	10.0	16.0	11.0	30	27
	25×19	G 1	G ¾	40.0	18.0	90.3	30.0	11.0	22.0	16.0	36	32
2	6×9	G ¼	G ⅜	22.0	10.1	68.0	24.0	8.8	5.5	8.0	14	22
	9×12	G ⅜	G ½	25.0	12.0	78.0	27.0	10.0	8.0	11.0	19	27
	12×19	G ½	G ¾	30.5	15.0	90.3	30.0	11.0	11.0	16.0	22	32
	19×25	G ¾	G 1	35.0	17.0	102.0	33.0	12.0	16.0	22.0	30	41

(注意) 予告なしに、品質・性能・改善のため寸法を変更する事があります。