

自動調心玉軸受

—円筒穴形・テーパ穴形—



Order
注文例

型式

1206ATN-H
1204AKTN-H

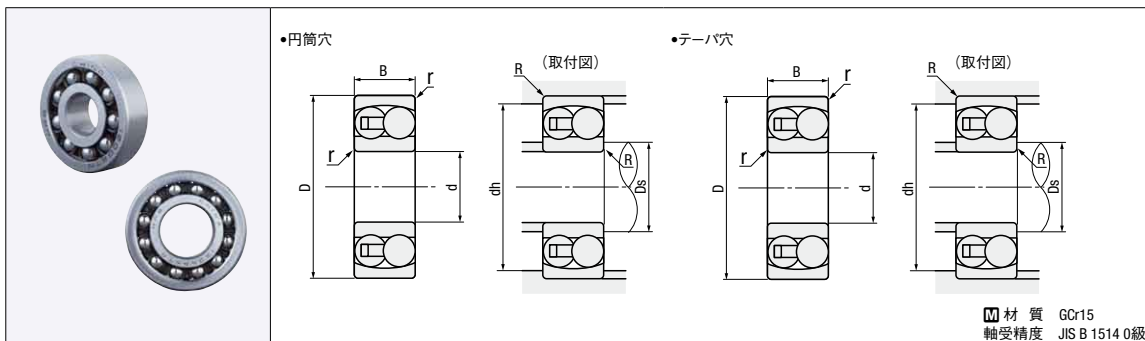

材質 GCr15
軸受精度 JIS B 1514 0級

型式		d	D	B	r (min.)	基本定格荷重		許容回転数rpm(参考)		取付寸法			質量 (g) (参考)
円筒穴	テーパ穴					Cr(動) N	Cor(静) N	グリース 潤滑	オイル 潤滑	Ds (min.)	dh (max.)	R (max.)	
1200ATN-H	-	10	30	9	0.6	5060	1180	24000	30000	14.0	26.0	0.6	33.6
1201ATN-H		12	32	10		5580	1480	22000	28000	16.0	28.0		41.1
1202ATN-H		15	35	11	7470	2010	19000	24000	19.0	31.0	49.7		
1302ATN-H			42	13	1.0	9520	2630	17000	20000	20.0	37.0		96.6
1303ATN-H		17	47	14	0.6	11800	3330	14000	17000	22.0	42.0		131.0
1204ATN-H	1204AKTN-H	20			1.0	12700	3400	15000	18000	25.0		116.0	
1205ATN-H	1205AKTN-H	25	52	15	1.0	14300	4000	13000	16000	30.0	47.0	1.0	139.0
2205ATN-H	-			18		16000	4470	11000	14000				158.0
1305ATN-H	-	30	62	17	1.1	18100	6000	9500	12000	31.5	55.5	1.0	250.0
1206ATN-H	1206AKTN-H			16	1.0	15600	4650	10000	13000	35.0	57.0		219.0
2206ATN-H	-	20	23800	6580	9500	12000	251.0						
1207ATN-H	1207AKTN-H	35	72	17	1.1	18000	6230	9000	11000	41.5	65.5	1.0	305.0
2207ATN-H	-			23		30500	8720	8500	10000				385.0
1208ATN-H	-	40	80	18	1.1	18500	6950	7500	9000	46.5	73.5	1.0	393.0
2208ATN-H	-			23		31800	10100						6700
1308ATN-H	1308AKTN-H	45	90	33	1.5	33800	11400	6700	8000	48.0	82.0	1.5	673.0
-	2308AKTN-H			54200	15900	6300	7500	897.0					
1209ATN-H	1209AKTN-H	45	85	19	1.1	21700	9560	7500	9000	51.5	78.5	1.0	473.0
2209ATN-H	-			23	32000	10600	7000	8500	526.0				
1309ATN-H	1309AKTN-H	50	100	25	1.5	38000	13400	6300	7500	53.0	92.0	1.5	932.0
1210ATN-H	-			90	20	1.1	26500	9150	7000				8500
2210ATN-H	-	23	33600		11300	6300	7500	559.0					
1310ATN-H	-	110	27	40	2.0	43300	14000	5600	6700	59.0	101.0	2.0	1170.0
2310ATN-H	-					63700	20000	5300	6300				1650.0

kgf=N×0.101972